

Heliport Lighting

LED Stake Mounted Perimeter Light

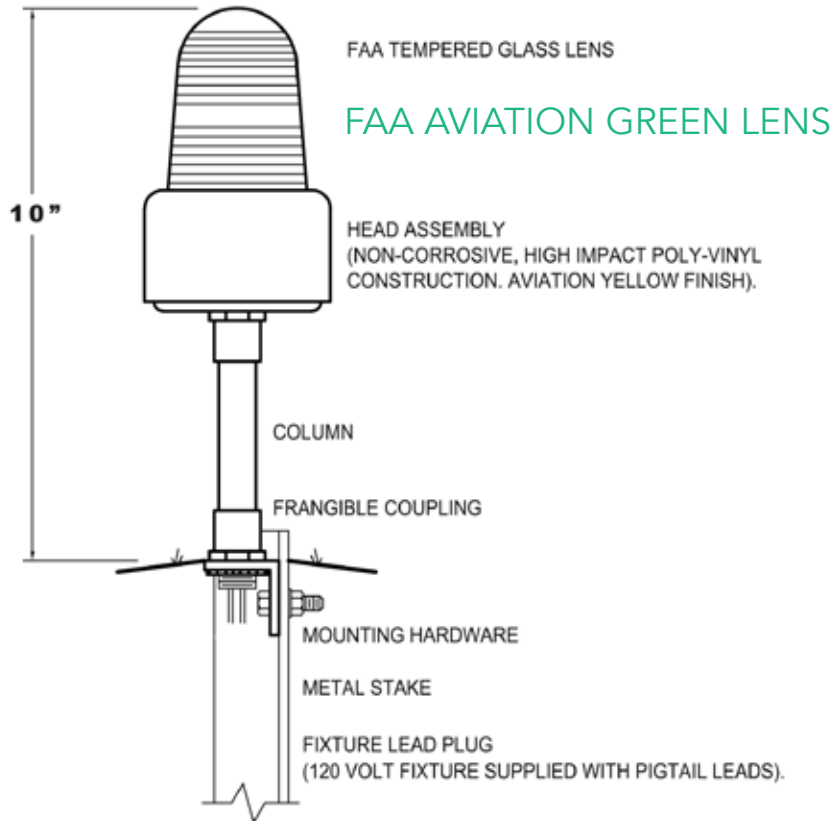

LED Canister Mounted Perimeter Light

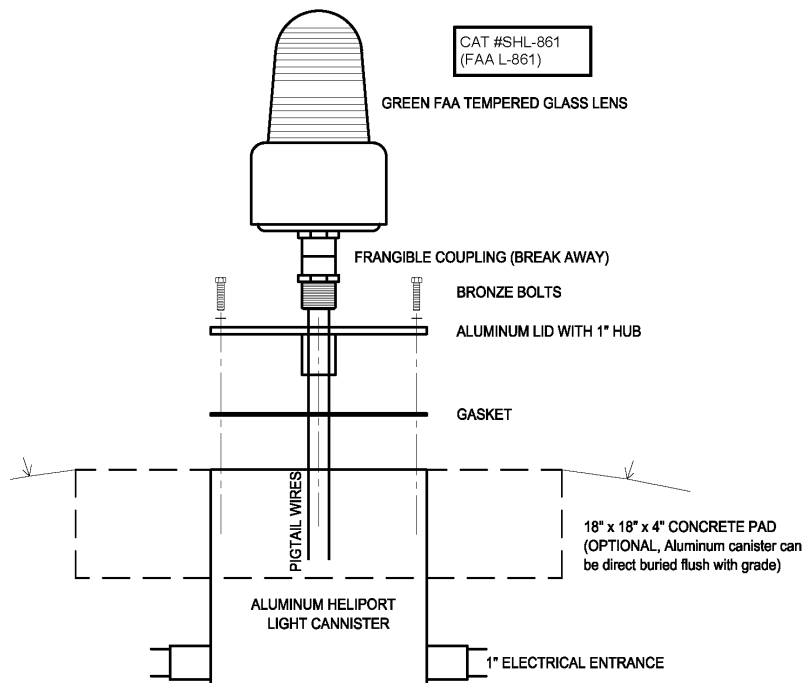

LED Surface Mounted Perimeter Lights

FOR HELIDECKS, OIL PLATFORMS, AND SHIP DECKS

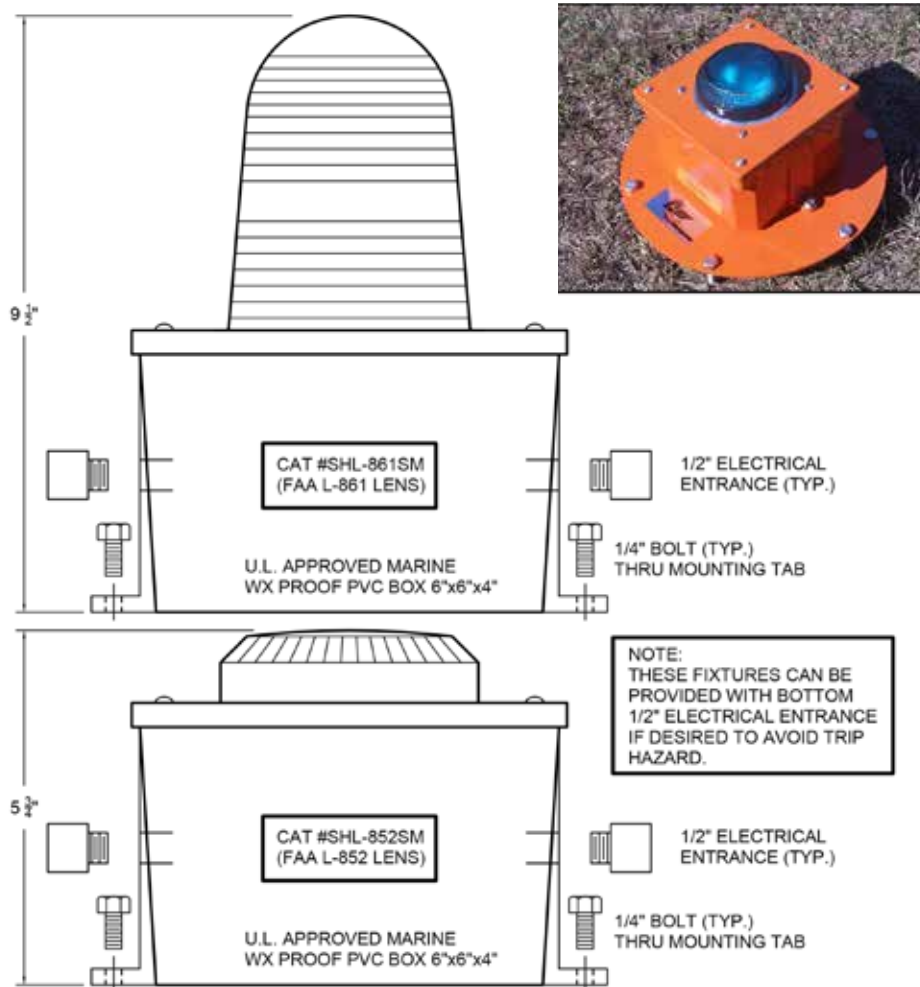

LED Semi-Flush Perimeter Lights

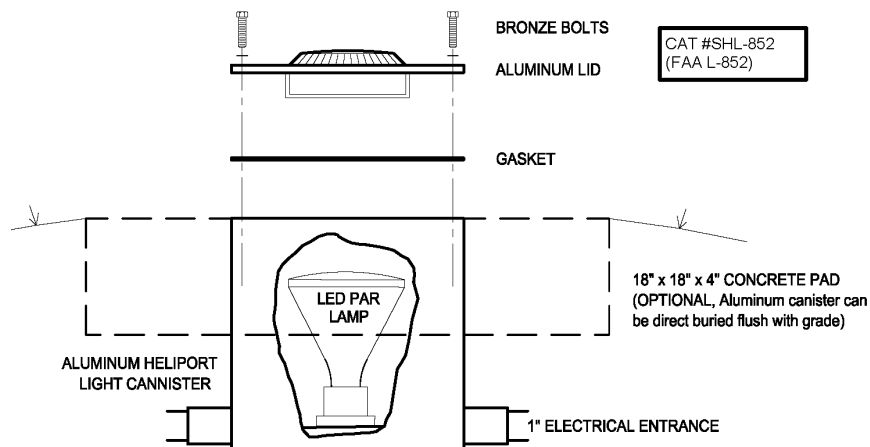

Striplin semi-flush heliport lights are mounted in a below ground aluminum canister. LED PAR 20 lamps are used to project a light beam up through an FAA L-852 type fresnel lens.

LED Heliport Pad Flood Lights

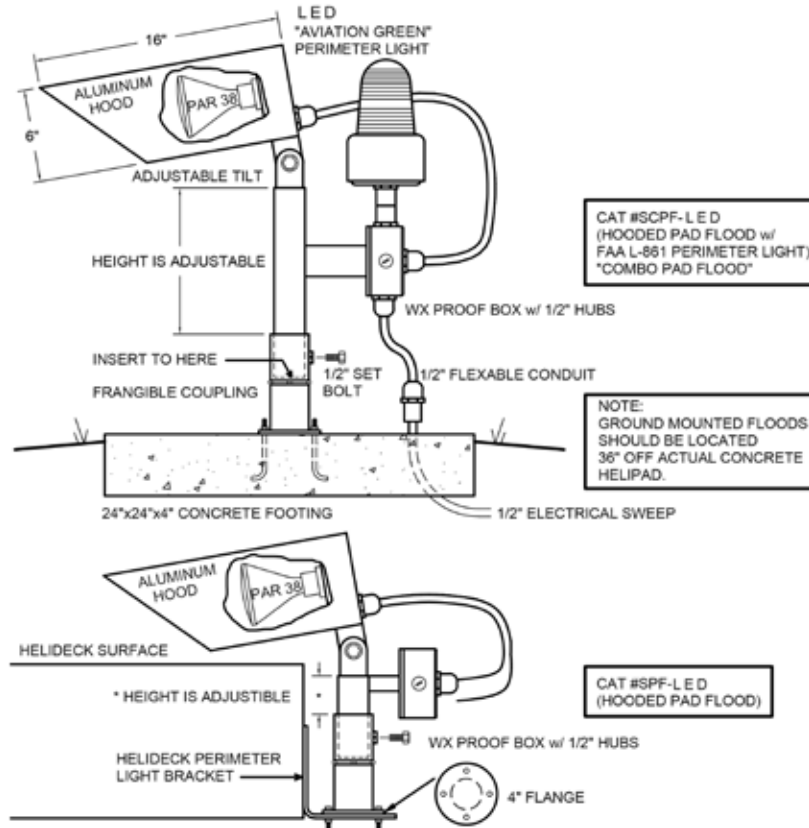

Medium and High Intensity Metal Halide Heliport Rotating Beacons

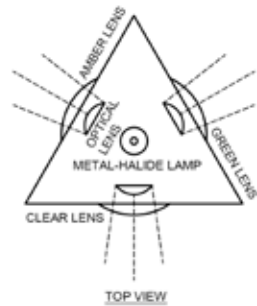

STRIPLIN MANUFACTURES TWO TYPES OF HELIPORT ROTATING BEACONS:

Medium intensity 250 watt metal halide heliport beacon. Cat #SHB-250

High intensity 400 watt metal halide heliport beacon. Cat #SHB-400

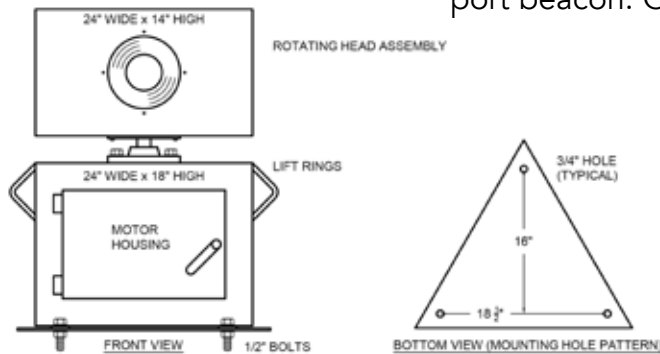

Striplin heliport beacons are constructed of aluminum and incorporate heavy bearings, large beacon shafts, and are driven by a heavy duty gear motor. High quality optical lenses project clear, green, and amber beams visible for up to 30 miles. Beacons rotate at an FAA specified 12 rpm.

LED Heliport Identification Beacon

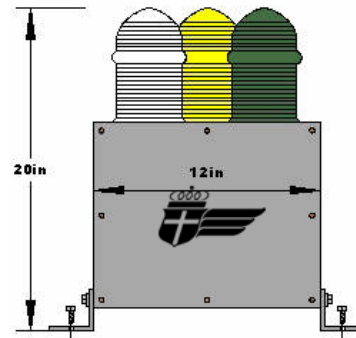

Identification beacon dimensions.

Identification beacons use LED lamps and a reliable mechanical flash unit (no printed circuit boards). Clear, green, and amber lights flash in sequence to identify a helicopter landing facility. Visibility up to 10 miles.

Heliport Windcone Assemblies

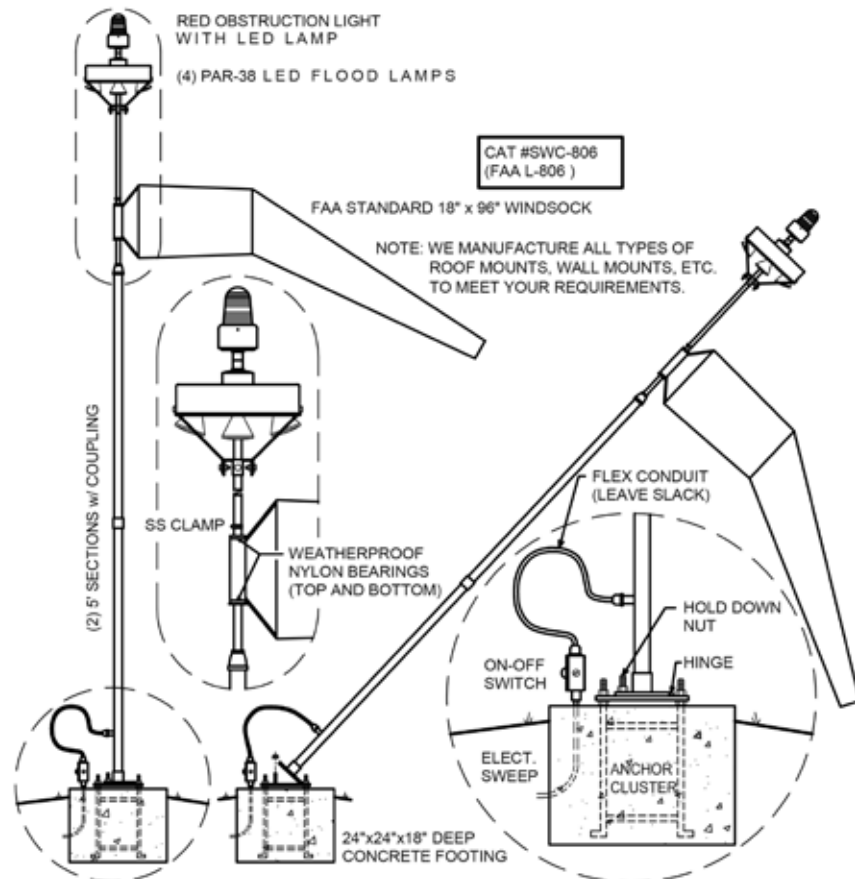

Striplin will manufacture windcone assemblies that can be mounted in any configuration that you may desire. Striplin also can supply replacement windsocks, windsock frames, and LED lamps. **CALL FOR QUOTE: (334) 588-3170!!!**

Heliport "In Pad" Helicopter Tie Downs

Aluminum canister type tie downs to be placed in concrete helipads, usually in groups of four.

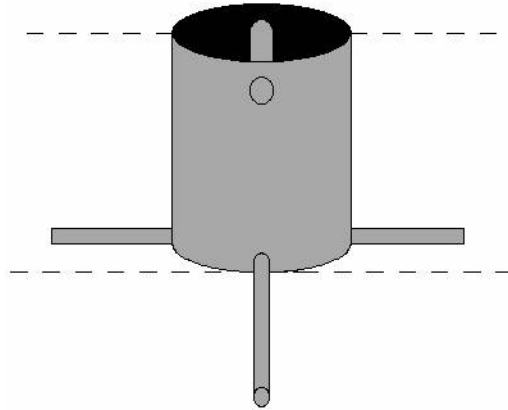

Heliport Ball Wire Markers

Ball wire markers are used to mark power lines in the vicinity of heliports. Fiberglass ball markers come in multiple sizes and are available in standard "safety orange" or with reflective tape.

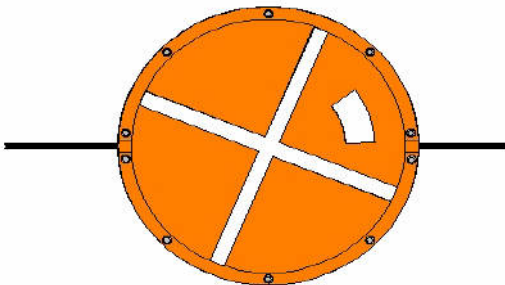

STRIPLIN RUNWAY LIGHTS

**CALL FOR QUOTE
(334) 588-3170**